



**Whiting Equipment Canada Inc.
Trambeam**





What TRAMBEAM® Cranes and Monorails can do for you

Today, when the cost of materials is measured to the fraction of a penny and technology has advanced the manufacturing processes to peak efficiency, production managers are seeking ways to improve output by speeding the flow of materials through the plant and by increasing the productivity of unused space.

Trambeam Overhead Materials Handling Systems are providing industry with important advantages available only when material is moved overhead. All movement is out of the way of men, materials and machines. Trambeam dovetails with other types of handling equipment – conveyors, chutes, hoists, yard cranes and floor trucks. It has the flexibility to meet facilities change and expansion. Trambeam fulfills the basic requirements of any good handling system by providing speed, efficiency, ease of operation, and economy.

A look through the following pages will show how Trambeam systems are moving materials overhead for many leading manufacturers. We hope it will suggest how Trambeam can bring improved economy and efficiency to your plant.

TRAMBEAM® Crane Systems

These highly efficient material handling units are used to move almost every conceivable type of material in practically every industry. They offer complete plant coverage, dependable performance and long life.

Available for rated loads to 30 tons, Trambeam cranes are manufactured with as many standard components as possible to provide quality equipment

at a reasonable cost. Where standard components are not suitable for a particular application, special combinations of components are used to provide the best suited equipment for the application.

All Trambeam cranes are essentially the same in construction and vary only in capacity and span. They consist of a Trambeam bridge girder fitted to end trucks that operate on the lower flange of the

Single Girder Cranes

These cranes are available for rated loads to 10 tons and in spans up to 100. With 20 bridge girders and 28 end trucks to select from, Trambeam single girder cranes are precisely engineered for each particular application. Induction-hardened, forged steel wheels, tapered roller bearings for most applications, the extra strength of Type SW bridge girders, heavy-duty tractor drives for all motor driven cranes — all of these features add up to dependable performance and long life.



Double Girder Cranes

These cranes are generally used on systems incorporating long spans, up to 100, and where heavier loads are handled, up to 30 tons. They require a minimum amount of headroom and can be used in handling lighter loads, where maximum lift is essential. The same high-quality components used in single girder construction are used on double girder cranes, quality which delivers dependable, trouble-free performance.

runways. The runways consist of at least two and as many additional parallel tracks as may be required to cover the desired area. Cranes may be either single or double girder construction depending upon rated load, and available headroom.

Cranes may be hand-propelled, hand-racked, or motor driven depending on the travel distance, frequency of operation, span, elevation and rated load. Trambeam

design has made possible the utilization of hand-propelled cranes — and their accompanying economies — to a greater extent than ever. However, motor driven cranes will increase the efficiency of a system by enabling the operator to do more work, in less time, with greater accuracy, and without fatigue. The motor driven crane will generally pay for its additional cost in a relatively short period of time as well as improve employee morale.



Gantry Cranes

Where no building structure exists or where work areas are to be served repetitively, Trambeam gantry cranes provide an efficient handling tool. One of the most common applications is single leg gantry cranes servicing individual work areas in the same bay in which an overhead traveling crane operates. The gantry cranes handle loads within their work areas while the overhead crane handles loads in and out of the work areas and heavy loads over the entire bay. The result is a more efficient operation since wasted man hours in waiting for crane service are eliminated. Gantry cranes represent a lower overall investment since fewer overhead cranes are required.

Transfer Cranes

The underhung feature of Trambeam makes it possible to offer systems where loads can be transferred from area to area without re-handling. The crane girders are equipped with interlock mechanisms which permit carriers to transfer from crane to crane either directly through a fixed transfer section or from a crane to a spur track.

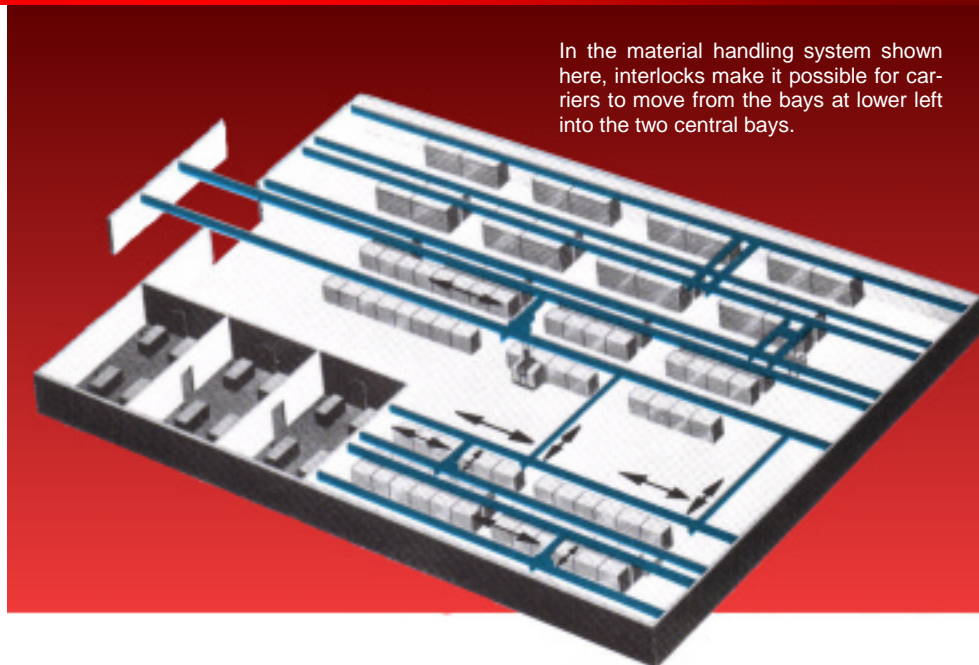

In the material handling system shown here, interlocks make it possible for carriers to move from the bays at lower left into the two central bays.

TRAMBEAM® Monorail Systems

Simple enough to be easily maintained, rugged enough to handle heavy loads, flexible enough to suit a variety of handling operations, Trambeam monorail systems are noted for their work-saving performance and complete reliability. Because they move materials over a predetermined path and because they can be precisely controlled by automated methods, these systems are ideal for processing of material. Weighing, cleaning, painting and other operations can be accomplished without removing the material from the carrier. In such operations, precise control of movement is essential, and industry has capitalized on Trambeam monorail systems to handle loads weighing a few ounces or thousands of pounds with a minimum of manpower. These systems improve plant operations by reducing floor traffic and they are designed for an unusually high degree of dependability. And the inherent efficiency and speed of Trambeam monorail systems can be developed to utilize switches, lift sections, and other accessories to further reduce labor costs and effect an increase in productivity.



Precise Handling

An unusually sensitive job of materials handling is illustrated here. Hot metal is poured into ladles on cab operated carriers from holding furnaces. The metal is then transported via the distribution monorail to pouring monorails where it is transferred into smaller ladles on floor-controlled carriers for pouring into molds. Slagging operation is shown here.

Switches

Trambeam switches greatly increase the versatility of a system. They are used for bypassing traffic, to divert loads to other areas or by connecting a spur line to the main system. Manual or motor operated, all are designed with positive locking devices.



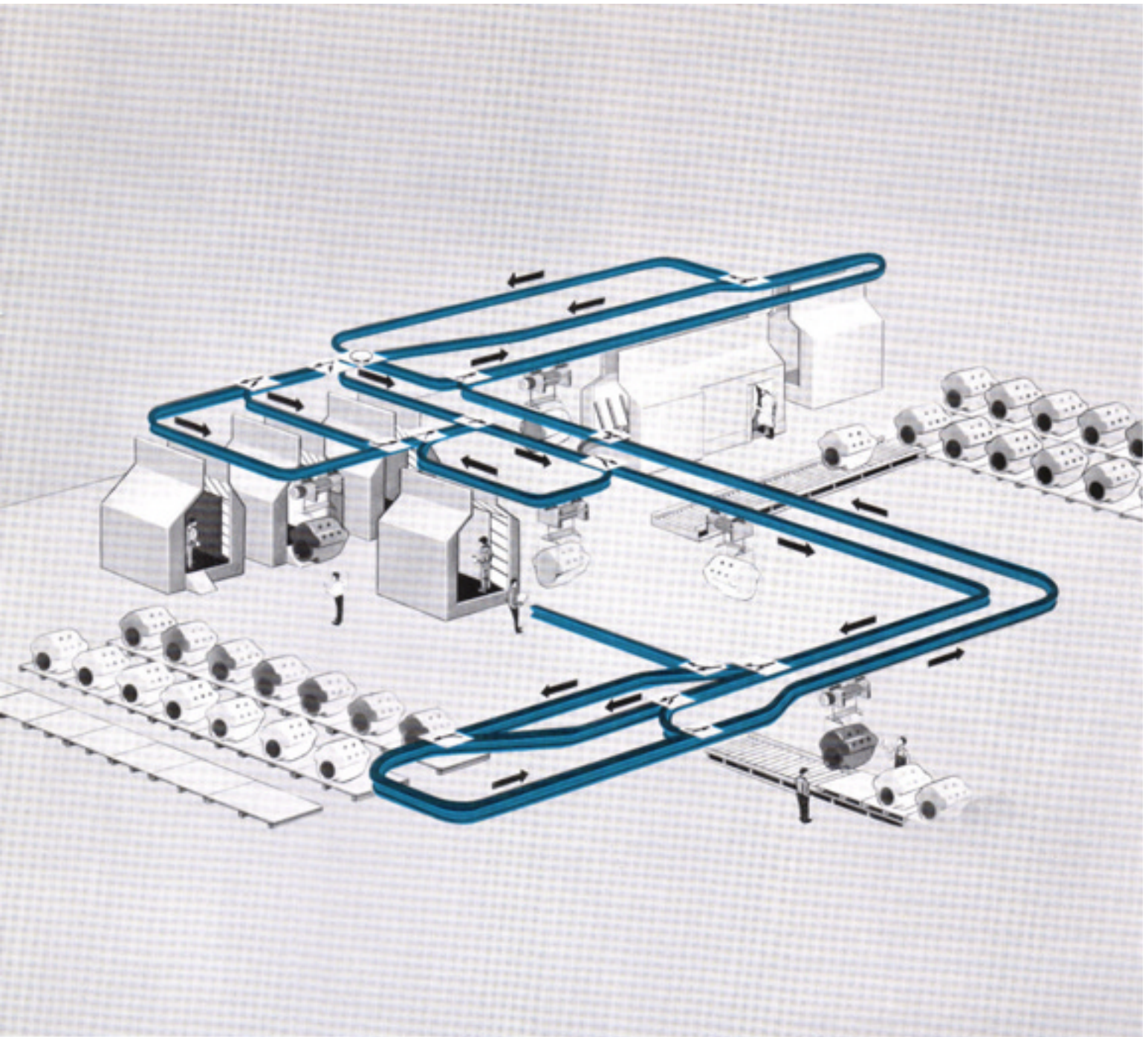

An Automated System

An automated system, as shown in the schematic drawing, speeds production of Diesel engines. Completed engines are cleaned and painted on a continuous basis with little or no manual handling. The engine is picked up by a Trambeam carrier and is not re-handled until it is set down on a shipping skid in the dock area.

Engines are sequenced through the stages of washing, prime and finish painting, drying and inspection on demand. Putting the production line in the air space a few feet above the floor leaves the area uncluttered and places the engines in convenient position for processing.

Trambeam® Track

Stronger, Longer Wearing

Trambeam tracks are manufactured using various thicknesses and widths of top flange and web plates and two rail sizes. Light rails have a 7/16 in. thick load carrying flange and heavy rails have an 11/16 in. thick flange. A 3¼ in. uniform width of the load carrying flange is maintained regardless of the load or depth of the track. This allows interchangeability of carriers and provides an efficient and economical overall system.

Computer selected top flange and web plates combine with the alloy steel rails to provide a balanced design for most applications. However, it is impossible to have a balanced design for all spans and capacities even though 18 standard sizes of track are available. Where a standard section is not suited for an application and where it is economically feasible to do so, a special optimum section can be furnished. These optimum sections are computer designed to the exact loading condition you may require and have the advantage of less weight and lower cost.

Light Rail Sections

Five sizes of light rail sections are available and are satisfactory for use as runway and monorail tracks and bridge girders. These tracks are used with carriers or end trucks having 5 in. diameter wheels or less.

Heavy Rail Sections

Eight sizes of heavy rail sections are available and are satisfactory for use as runway and monorails tracks and bridge girders. These tracks are used with all sizes of Trambeam wheels.

Bridge Girders

Five sizes of bridge girders are available and use heavy rails with 11/16 in. thick load carrying flanges. They can be used for runway tracks but an optimum track section will generally be more economical. They are furnished with stiffeners between the top flange and web plates and are used with all sizes of Trambeam wheels.

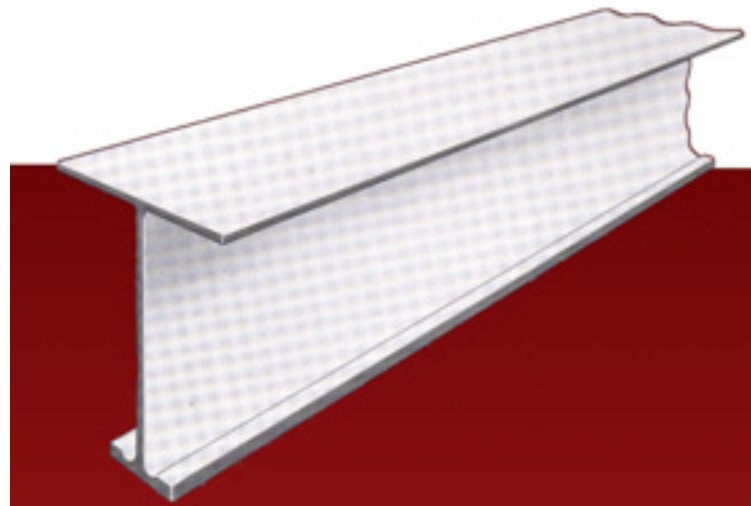

Light Rail Sections

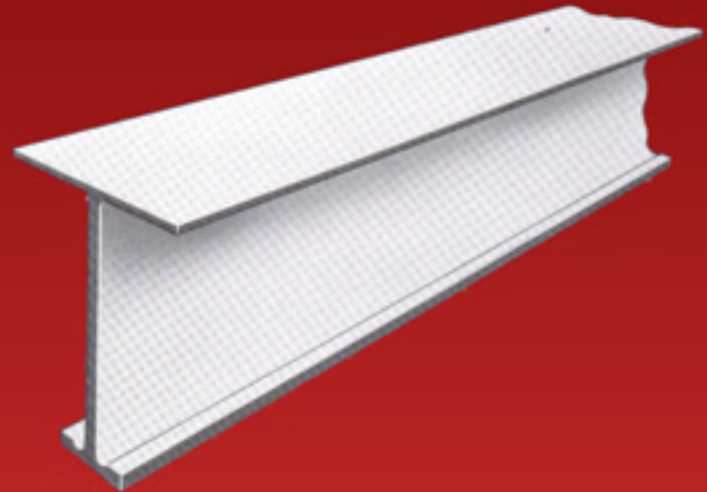

Heavy Rail Sections

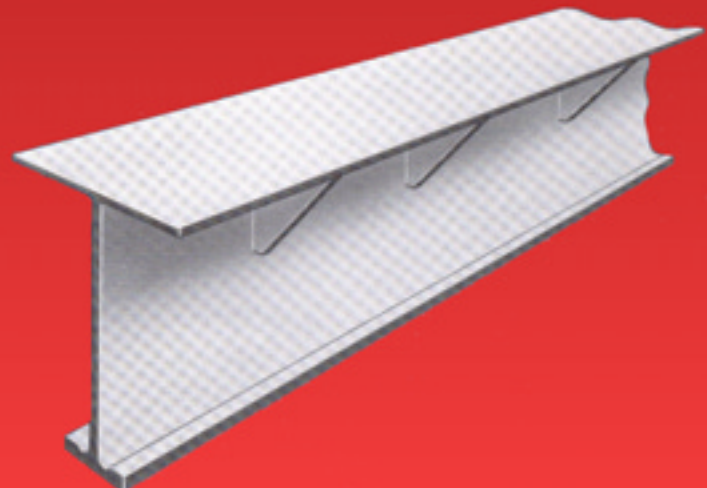

Bridge Girders

End Trucks

Trambeam end trucks have been engineered for peak performance. A minimum of maintenance is required and it is usually performed during routine inspection. Three series are manufactured . . . light duty single girder, standard single girder and double girder end trucks. End trucks for light duty, single girder cranes are available in capacities of 2,400 and 4,000 pounds.

Single Girder End Trucks

A complete line of 4 and 8 wheel end trucks is available for standard single girder cranes in capacities from 4,000 to 30,000 pounds. Load bars are fabricated from steel channels and are precisely machined to control vertical elevation and squareness. A rigid connection between the truck and bridge girder is provided by a close-tolerance key plate welded to the girder and a key slot machined in the load bar. See illustration.

Double Girder End Trucks

Double girder end trucks are available in 4, 8, and 16 wheel types and in capacities from 8,000 to 60,000 pounds. Load bars are fabricated from steel channels and are precisely machined to control vertical elevation and squareness. Rigid connections are provided between the bridge girders and end trucks by keys which are welded to the load bars when the crane is assembled at the factory.

Forged Steel Wheels

The tread and bore of the forged steel wheels are accurately machined for concentricity. The flange and tread areas are induction hardened to a minimum hardness of 425 Brinell. The hardened wheels in combination with the flat tread Trambeam track provide hard, smooth running surfaces and require just minimum effort to propel a crane along the runway. The wheels are equipped with precision, anti-friction bearings. Wheels on lighter capacity end trucks operate on prelubricated and sealed ball bearings. Wheels on heavier capacity end trucks have double-row tapered roller bearings which are lubricated through fittings in the wheel axle.



Single girder 4-wheel end truck driven by a No. 24-9 tractor drive.



Close tolerance key plates are accurately aligned by an optical instrument and welded to the bridge girder of a single girder crane. The key plates fit into key slots machined in the end truck load bars and provide rigid and square connections of the girder to the trucks.

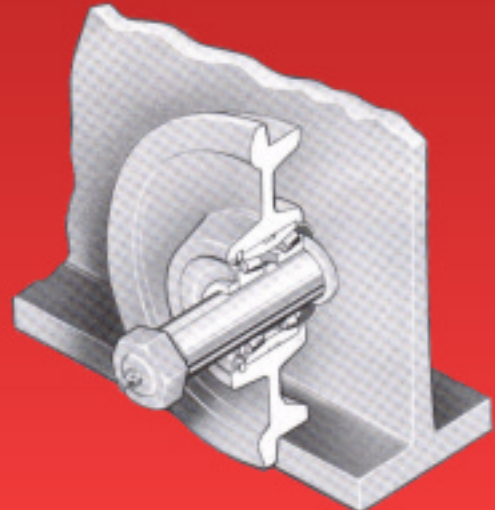

Wheels with double row tapered roller bearings were pioneered by Trambeam more than 60 years ago.

TRAMBEAM® Carriers

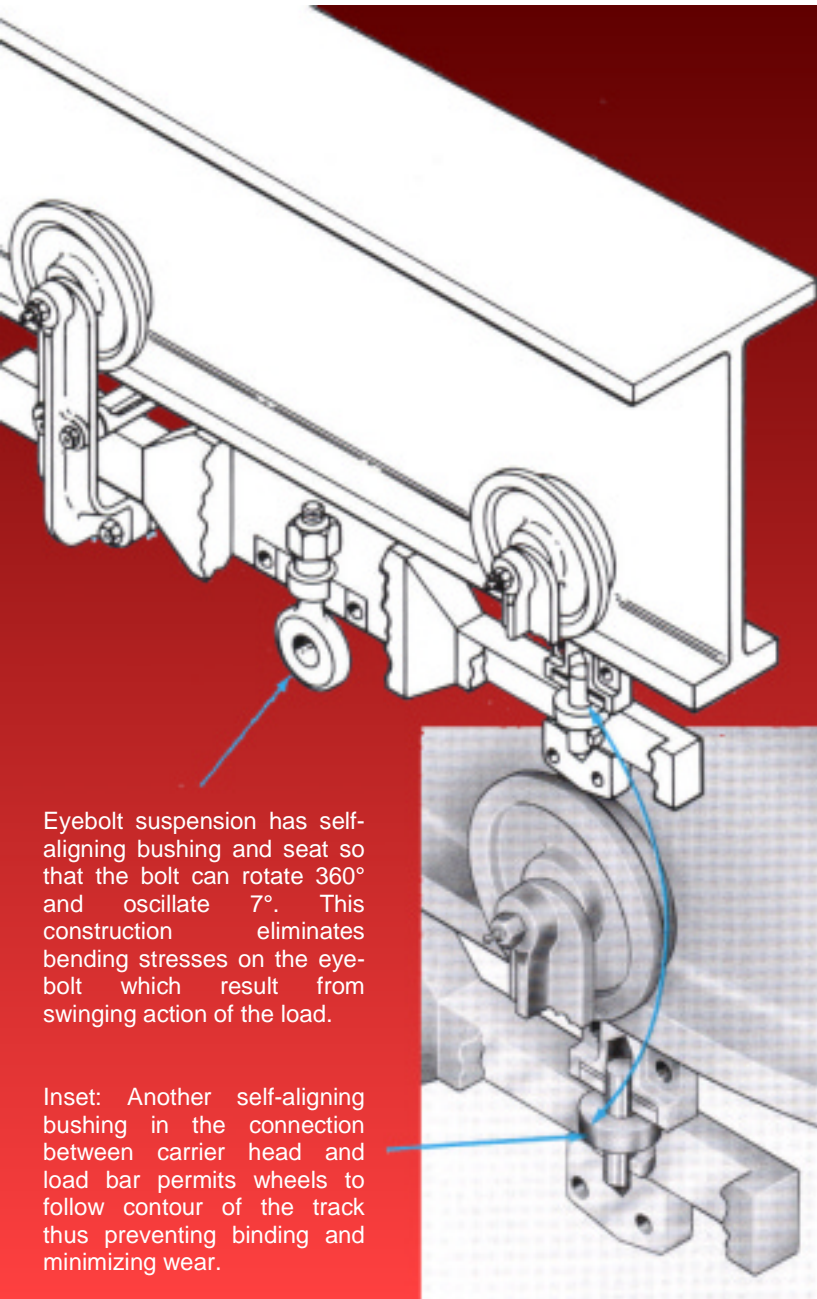

Eyebolt suspension has self-aligning bushing and seat so that the bolt can rotate 360° and oscillate 7°. This construction eliminates bending stresses on the eyebolt which result from swinging action of the load.

Inset: Another self-aligning bushing in the connection between carrier head and load bar permits wheels to follow contour of the track thus preventing binding and minimizing wear.

Since the efficiency of an overhead handling system is dependent directly on the carriers, Trambeam has laid particular stress on developing a line of manual and motor-driven carriers possessing outstanding quality.

The free-swiveling action designed into the carrier heads assures equal wheel loading thus reducing the effort needed to move the carrier. Other features include yokes of structural or forged steel, forged wheels with induction-hardened treads and flanges, properly proportioned wheelbase, forged steel eyebolts with a specially designed swiveling action to eliminate stresses which could result from the swinging action of the load.

Curved monorail and runway tracks on high speed systems are especially vulnerable to wear. To avoid undue maintenance in these situations, Trambeam carrier heads are available with flangeless wheels and side guide rollers which reduce friction and wear on the track.

Trambeam® Gimbal Suspension System

The gimbal suspension system uses multiplane washers at each end of the hanger rod to provide a gimbal assembly. The tapered planes on the top surface of the washers are positioned at right angles to the tapered planes on the bottom surface. This allows free rod movement of 6 degrees in any direction.

Two sizes of rods are available – 3/4 inch diameter rated at 8,500 pounds per rod and 1-1/8 inch diameter rated at 20,000 pounds per rod. Single and double rod suspensions are used for hanger rod loads up to 40,000 pounds.

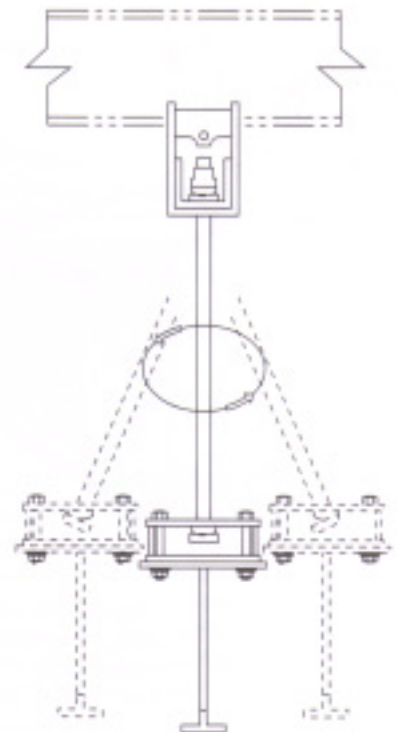

Trambeam® Drives

Trambeam provides two types of drives, a motor driven head and a tractor drive, which are used for propelling Trambeam cranes and carriers. Each is available in a wide range of speeds and horsepower selections. Each drive operates as an individual unit and will eliminate the necessity of a squaring shaft between the trucks.

Motor Driven Head

The motor driven head drive uses a geartrain, which propels the load through contact with the top of the tread.

Tractor Drive

The tractor drive uses a spring loaded polyurethane covered drive wheel rotating against the underside of the track. Driving traction is independent of the load and is manually adjusted by spring pressure.



No. 24-8 tractor drives are available with speeds up to 450 PPM and motors up to 5 horsepower.



No. 24-9 tractor drives are available with standard speeds of 100, 125, 150, 175 and 200 PPM with 1/2, 3/4, 1 and 1 1/2 HP motors.

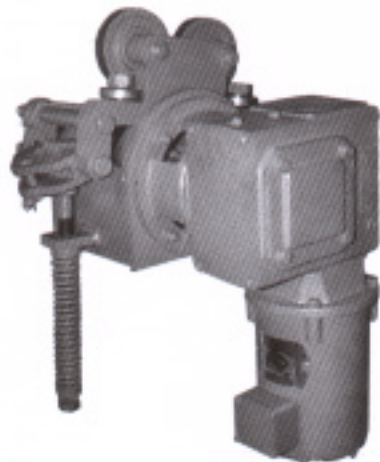

No. 24-10 tractor drives are available with standard speeds of 55 and 90 FPM and with 1/2, 3/4 and 1 horsepower motors.

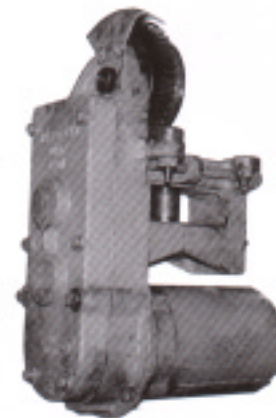

No. 26-1 motor driven head drives are available with standard speeds of 75, 100, 130 FPM and with 3/4 and 1 horsepower motors.

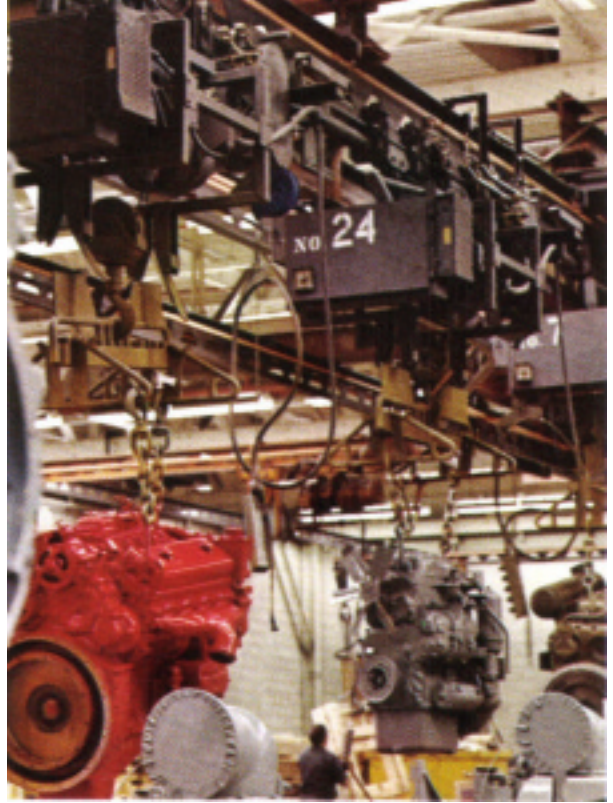

Let us help you plan

Trambeam materials handling systems are distributed through experienced distributors who can help you plan for improved efficiency in your plant.

Trambeam cranes and monorail systems have the versatility to combine cost savings with high utility. Single and double girder cranes, monorail systems, manually operated or fully automated can give you accelerated product flow through your plant at a reasonable capital investment.

Call on your Trambeam team. They can help you plan for full utilization of your plant facilities at the right price.

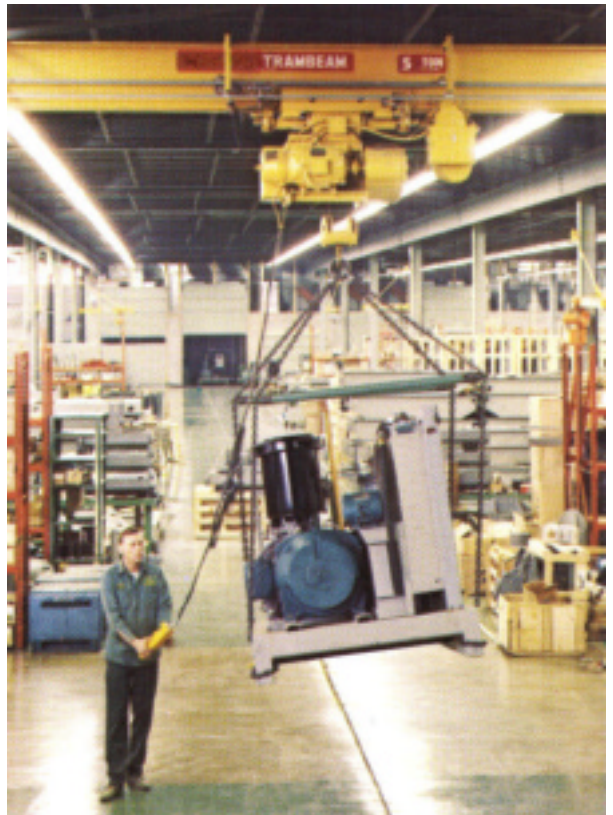

Whiting Equipment Canada Inc.



www.whiting.ca

Mike Cosoletto, CET, BBE
350 Alexander Street
Welland, Ontario L3B 2R2 CDN
Tel (+1) 905-732-7585 ext. 271
Fax (+1) 905-732-2366
E-Mail mcosoletto@whiting.ca