

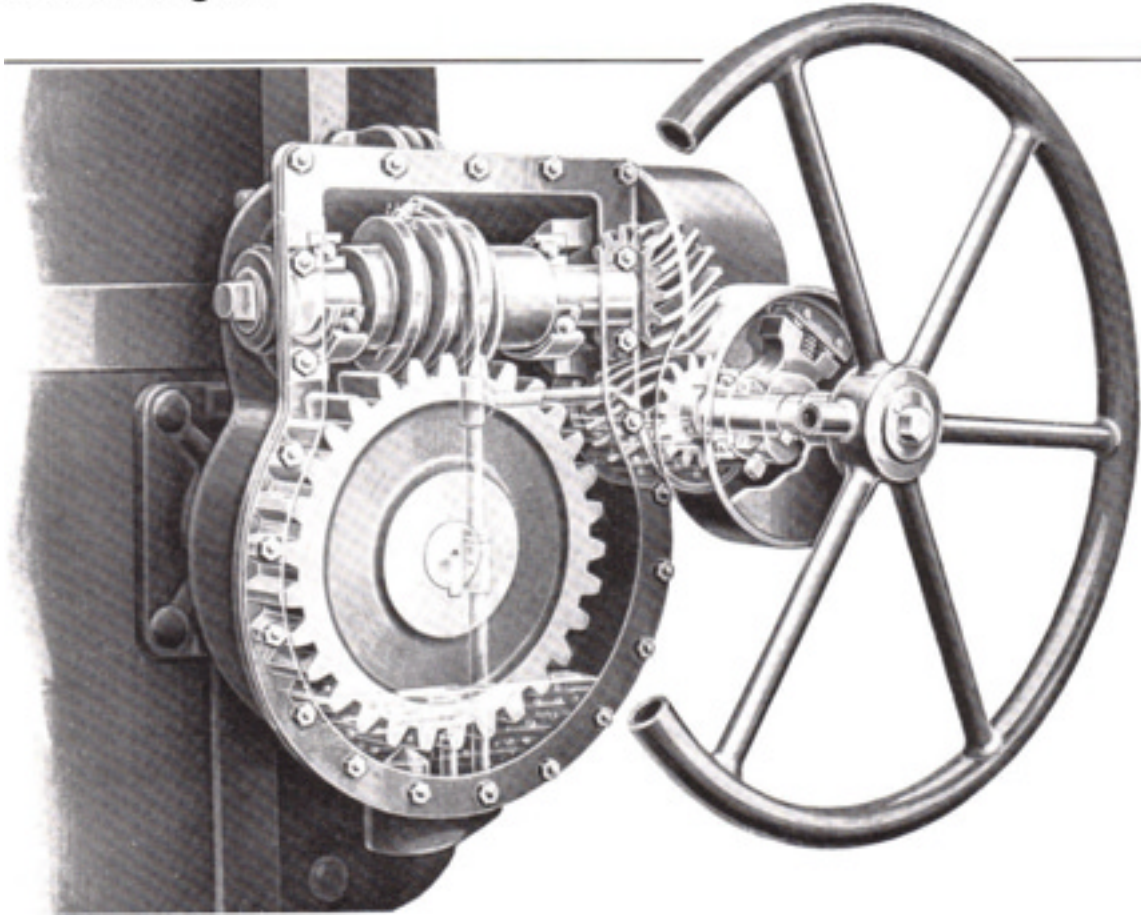

www.whiting.ca

“E-Z POUR” LADLE GEARING WITH STANDARD AUTOMATIC BRAKE



Proven in thousands of hours of operation in foundries and mills throughout the world, Whiting E-Z POUR™ LADLE GEARING offers an efficient, economical means of pouring for ladles 20½” to 100” top diameter. Available for motorized as well as manual operation, this versatile unit requires minimal attention and service.

“E-Z POUR” LADLE GEARING includes a standard automatic brake designed to prevent the ladle from tilting unless torque is applied to the handwheel. As the handwheel is turned, the brake disengages for movement of the ladle. Full or empty, the ladle is held in any given position until the handwheel is turned. This unique construction feature is a built-in guard against “running down.”

Mechanical life of “E-Z POUR” LADLE GEARING is preserved by automatic lubrication. Each time the handwheel is turned, an integral pump automatically forces fresh oil to all moving parts. Lubrication maintenance involves only periodic checking of the oil

level, with an annual oil change recommended. This automatic lubrication feature substantially lengthens the life and operational efficiency of gears and bearings without involving costly and time-consuming maintenance.

“E-Z POUR” LADLE GEARING is easy to operate. Helical, worm gears and anti-friction bearings are used in combination for fast, accurate pouring with minimal effort. The operator controls the pouring stream within a fraction of an inch, reducing the possibility of a sudden, costly “drop.”

“E-Z POUR” LADLE GEARING is a self-contained unit, mounted on the trunnion independent of the bail. Gear alignment is not affected by distortion of either bail or bowl. Adjustment of all gears contributes to efficient operation by preventing excessive backlash.

Its simplicity of design makes “E-Z POUR” LADLE GEARING the first choice among experienced operators, and the most efficient, economical means of tilting a ladle.

REMOVING LADLE GEARING

WARNING: ENGAGE THE BAIL LOCK BEFORE SERVICING OR REMOVING THE LADLE GEARING

FAILURE TO DO SO WILL ALLOW THE BAIL TO DROP OR THE LADLE TO TILT AND MAY CAUSE SERIOUS INJURY TO PERSONNEL.

Remove filler plug (3) and drain plug (2). After the oil has drained, remove cover (T). Remove cap screw and lock washer (5) and pull the gib key (13). The complete ladle gearing can now be removed from the trunnion shaft.

CAUTION! LADLE GEARING IS EXTREMELY HEAVY. DO NOT ATTEMPT TO REMOVE IT WITHOUT ASSISTANCE FROM MATERIAL HANDLING EQUIPMENT

NOTE: REMOVING THE BAIL LUG WILL ALLOW A BOLT TO BE INSTALLED THRU THE HOLE IN THE BAIL LUG SOCKET (12) TO FACILITATE LIFTING.

INSTALLING LADLE GEARING

(See Caution and Note above)

Align the keyway in spur gear (A) with the keyway in the ladle trunnion shaft. Slide the gearing onto the shaft until it contacts the shoulder or the spacer, depending on the ladle design. Install the gib key (13).

CAUTION! THE KEY MUST FIT SNUGLY IN THE KEYWAY AND THE KEY MUST BE FLUSH WITH OR EXTEND SLIGHTLY BEYOND THE END OF THE TRUNNION SHAFT WHEN FULLY SEATED. AN UNDERSIZE KEY THAT IS LOOSE IN THE KEYWAY OR DOES NOT REACH THE END OF THE TRUNNION SHAFT MUST BE REPLACED.

Install the cap screw and lockwasher (5), cover (T) and drain plug (2). Remove the bolt from the lifting hole (12) in the bail lug socket and install the bail lug.

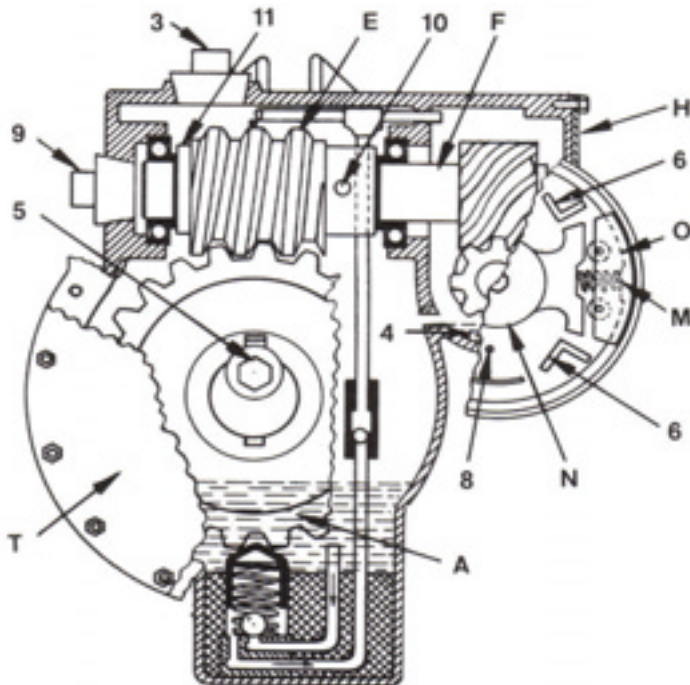

CAUTION! THE BAIL LUG MUST FIT SNUGLY INTO THE SOCKET (.002" TO .005" MAXIMUM CLEARANCE) TO PREVENT THE LADLE FROM ROCKING. AN INTERFERENCE FIT MAY MAKE THE LADLE HARD TO TURN.

Install oil drain plug (2), fill gear case indicated to the oil level on the sight gauge (1) with S.A.E. 90 E.P motor oil and install the filler plug (3).

SPUR GEAR

The L-1010 is supplied with a one-piece gear made of ductile iron. The gear has two keyways so it can be rotated 180° if the teeth on one side wear excessively.

The L-992, L-1016 and L-1040 have ductile iron ring gears attached to machined steel hubs with turn bolts. This feature permits the gear to be rotated on the hub to compensate for wear

LUBRICATION

Because lubrication is automatic, only periodic checks and refills are required.

To check oil pump operation, remove the pipe plug (3) and turn the handwheel. If the pump is operating properly, oil will be emitted from the oil line onto the worm. Oil will also be pumped into the reservoir (4). If no oil is pumped, Check the level in the gear case at the oil level gauge. Refill oil at the level (1).

NOTE: OIL SHOULD BE CHANGED AT LEAST ONCE A YEAR.

Use S.A.E. 90 E.P motor oil, and keep filled to the level indicated on the oil level sight gauge.

SHOE BRAKE

The WHITING "E-Z POUR" LADLE GEARING Shoe Brake operates in the following manner:

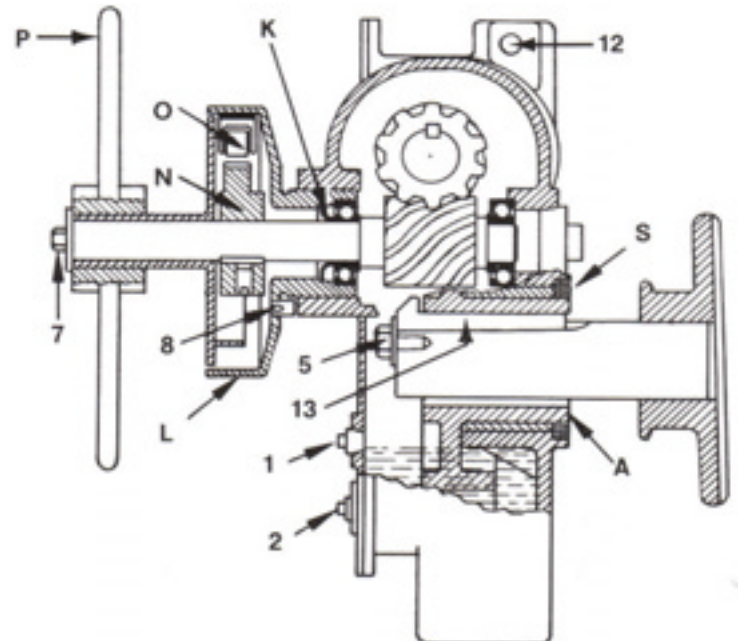

As the handwheel (P) is turned, one of the lugs (6) engages the brake shoe (O) and simultaneously drives the cam (N). Brake action is prevented, and the gear train is turned.

If a torque is applied to the gear train by the weight of the ladle, the cam (N) will contact the rollers on the brake shoe (O) forcing the brake shoe against brake drum (L) and prevent the ladle from tilting.

WARNING: DO NOT USE LADLE IF BRAKE SHOE HAS BEEN REMOVED OR BRAKE ASSEMBLY IS DAMAGED OR DISABLED IN ANY MANNER.

SERIOUS INJURY TO PERSONNEL MAY RESULT AS LADLE MAY TIP

If the ladle over-travels, check the brake lining for wear, and replace the shoe if necessary. To inspect the brake, remove the cap screw (7) and handwheel.

WARNING! ENGAGE THE BAIL LOCK BEFORE MAKING ANY ADJUSTMENTS TO THE LADLE GEARING OR BRAKE.

FAILURE TO DO SO WILL ALLOW THE LADLE TO TIP OR THE BAIL TO DROP AND MAY CAUSE SERIOUS INJURY TO PERSONNEL.

CAUTION! KEEP THE BRAKE HOUSING AND SHOE FREE OF OIL OR GREASE AT ALL TIMES TO INSURE PROPER BRAKE ACTION.

If the brake lining is in good condition, and the braking action is still inadequate, replace the compression spring (M).

CAUTION! WHEN REPLACING THE HANDWHEEL, THERE MUST BE AT LEAST $\frac{1}{16}$ " GAP BETWEEN THE RETAINING WASHER AND THE HANDWHEEL HUB.

FAILURE TO PROVIDE THIS CLEARANCE MAY PREVENT THE BRAKE FROM FUNCTIONING PROPERLY AND MAY ALLOW LADLE TO TIP AND CAUSE SERIOUS INJURY TO PERSONNEL.

LADLE DROP

Ladle drop may occur after extensive use due to axial movement of the handwheel shaft or worm shaft.

To correct axial movement of the handwheel shaft, remove cap screw (7) and the handwheel. Remove the set screw(s) (8) and turn the brake drum (L) clockwise until snug. Do not tighten excessively. Center punch the housing through the set screw holes. Remove the brake drum and drill $17/32$ " Diameter hole(s) \sim/s " deep in the housing. Reassemble and tighten set screw(s) (8) into the drilled holes to lock the brake drum in place.

To check axial movement of the main worm shaft (F), remove pipe plug (9) and turn the handwheel in both directions. Axial movement of the shaft should be 0.002".

To eliminate excess movement, remove cover plates (H) and (T) and drive out taper pin (10) holding worm (E) on shaft (F). Push the worm so it contacts the bearing nearest cover (H). Measure the clearance between the shoulder of the worm and the face of the bearing at (11) with a thickness gauge. Make washer shaped shims 0.002" narrower than the measured clearance. Pull the worm shaft through the opening at the cover (H) until the shim can be inserted at (11). Push the worm shaft (F) back until the holes for pin (10) line up. Drive the taper pin (10) in place, and reassemble the covers.

MOTOR OPERATED "E-Z POUR"

"E-Z POUR" LADLE GEARING is available for motor operation. A hoist-type motor features a disc brake with hand release. A removable handwheel for emergency use during power failure is also furnished.

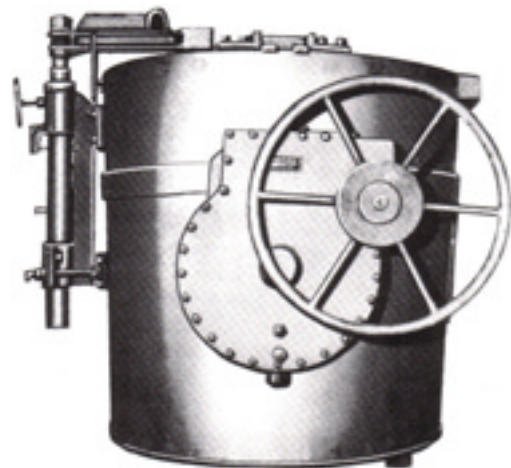
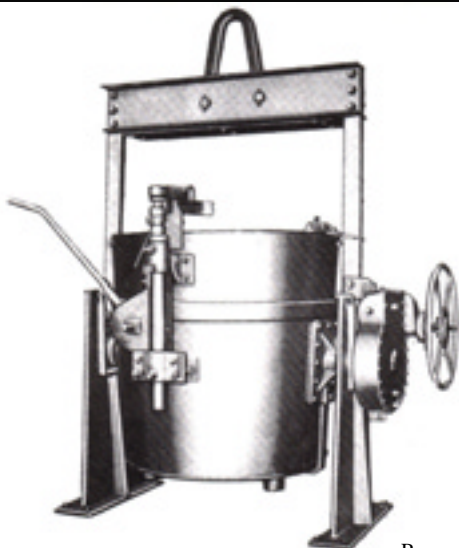

Rear and side views of bottom tap crane ladle with 5 Position Rig and E-Z Pour gearing.

WHITING "E-Z POUR" LADLE GEARING PARTS LIST

NOTE: When ordering parts, give the Whiting Requisition Number and the nameplate data or, if no nameplate, the gearing size (cast on top of the housing, i.e. L-1010. L-992. etc.) and the description of the part and part number.

Standard "E-Z POUR" LADLE GEARING is manufactured in four sizes: L-1010 for 20½" to 29" diameter ladles; L-992 for 32" to 40"; L-1016 for 44" to 55"; and L-1040 for 58" to 66".

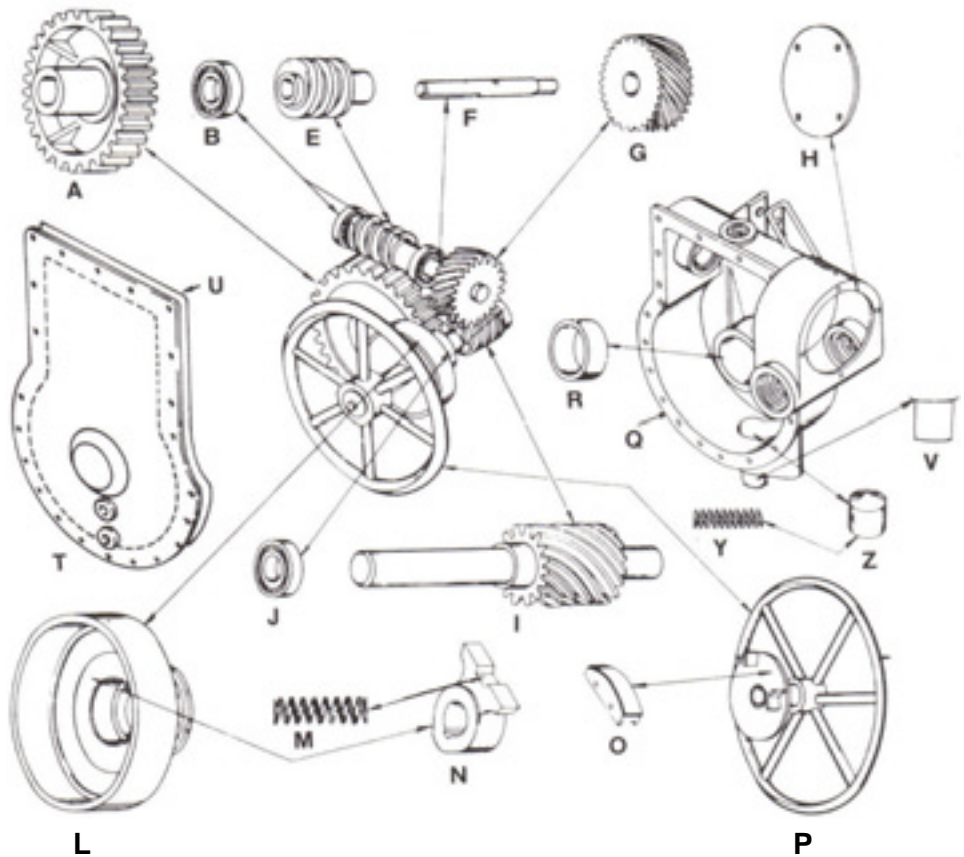

It is the policy of Whiting Corporation to continually improve its products. The right is reserved to make changes in specifications or design which, in Whiting's opinion, are in accordance with this policy, or which are necessitated by the availability of materials. The descriptions herein are for the purpose of identifying the type of equipment, and do not limit or extend the express warranty provision in any contract of sale.

†Spur Gears for L-992, L-1016 and L-1040 are comprised of a ring gear and hub. Should either of the two be required, order separately with the part numbers, indicated for the respective sizes.

*Not shown.

††For handwheel pulls greater than 30 lbs.. Whiting suggests ordering the motorized option. At 30 lbs. pull, the L-1040 has an output torque of approx. 27,900 lbs-in.

	DESCRIPTION ASSEMBLY DRAWING	L-1 010 U -70035	L-992 U -70036	L-1016 U -70037	L-1 040 U -80194
	ALLOW. OUTPUT TORQUE (LBS-INCH)	20½" to 29" 3,730	32" to 40" 9,000	43½" to 55" 17,700	58" to 66" 40,000
	MAX. HAND WHEEL PULL @ ALLOW. OUTPUT TORQUE (LBS.)	25	29	30	43††
†A	SPUR GEAR HUB (BORE)	5483770	5485520 5476850 (2 3/16) 5476860 (2 15/16)	5484360 5476080 (2 11/16) 5476090 (2 15/16)	5485460 5476550 (3 7/16) 5476520 (3 15/16)
B	BEARING	0420560	0420560	0420580	0421340
*C	STEEL SHIM	5473740	5473740	5473760	5473760
*D	STEEL SHIM	5473750	5473750	5473770	5473770
E	WORM	5473600	5473460	5475930	5487370
F	WORMSHAFT	5473620	5473480	5473700	5471110
G	HELICAL GEAR	5483980	5483740	5483740	5483740
H	COVER PLATE	5480520	5484310	5484310	5484310
I	HELICAL (PINION & SHAFT)	5473720	5473500	5473500	5473500
J	BEARING	0420510	0420540	0420540	0420540
*K	OIL SEAL (PINION SHAFT)	042009P	0427960	0427960	0427960
L	BRAKE DRUM	5484100	5484080	5484080	5484080
M	BRAKE SHOE SPRING	0427050	0427050	0427050	0427050
N	BRAKE CAM	5484070	5484030	5484030	5484030
O	BRAKE SHOE ASSEMBLY	5484130	5484130	5484130	5484130
P	HAND WHEEL ASSEMBLY	5476020	5475970	5476000	5475980
Q	GEAR CASE W/TRUNNION BUSHING	5483951	5483871	5484011	5482380 (upper) 548684X (lower)
R	TRUNNION BUSHING	5475080	5475100	5475120	5475140
*S	OIL SEAL (TRUNNION)	0425620	0425630	0425640	0427870
T	GEAR CASE COVER	5621750	5475330	5475340	5475400
U	GASKET (GEAR CASE COVER)	0275430	0275390	0275440	0275470
V	PUMP HOUSING	5470130	5470130	5470130	5470130
*W	PUMP HOUSING GASKET	5474020	5474020	5474020	5474020
*X	5/8 DIA. BALL (PUMP)	0423520	0423520	0423520	0423520
Y	PUMPSRING	0427160	0427160	0427160	0427160
Z	PUMP PLUNGER	5475850	5475850	5475850	5475850

Whiting Equipment Canada Inc.

Mike Cosoletto

350 Alexander Street
Welland, Ontario L3B 2R2 CDN
Tel (+1) 905-732-7585 ext. 271
Fax (+1) 905-732-2366
Email mcosoletto@whiting.ca

